



JWBS-10

BAND SAW

Original:

GB
Operating Instructions

Translations:

D
Gebrauchsanleitung

F
Mode d'emploi



TOOL FRANCE SARL

9 Rue des Pyrénées, 91090 LISSES, France

www.jettools.com

M-10000861M

2019-01



**CE-Conformity Declaration
CE-Konformitätserklärung
Déclaration de Conformité CE**

Product / Produkt / Produit:

Band saw
Bandsäge
Scie à ruban
JWBS-10

Brand / Marke / Marque:

JET

Manufacturer / Hersteller / Fabricant:

TOOL FRANCE SARL
9 Rue des Pyrénées, 91090 LISSES, France

We hereby declare that this product complies with the regulations
Wir erklären hiermit, dass dieses Produkt der folgenden Richtlinie entspricht
Par la présente, nous déclarons que ce produit correspond aux directives suivantes

2006/42/EC

Machinery Directive
Maschinenrichtlinie
Directive Machines

designed in consideration of the standards
und entsprechend folgender zusätzlicher Normen entwickelt wurde
et été développé dans le respect des normes complémentaires suivantes

EN ISO 12100:2010

EN 61029-1:2009+A11:2010

EN 61029-2-5:2011

Responsible for the Documentation / Dokumentations-Verantwortung / Responsabilité de Documentation:

Head Product-Mgmt. / Leiter Produkt-Mgmt. / Resp. Gestion des Produits
TOOL FRANCE SARL
9 Rue des Pyrénées, 91090 LISSES, France

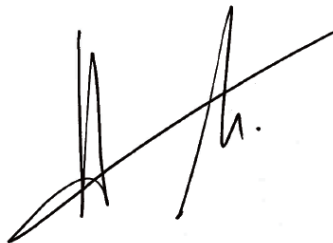

2018-12-25 Christophe SAINT SULPICE, General Manager

TOOL FRANCE SARL
9 Rue des Pyrénées, 91090 LISSES, France

GB - ENGLISH

Operating Instructions

Dear Customer,

Many thanks for the confidence you have shown in us with the purchase of your new JET-machine. This manual has been prepared for the owner and operators of a **JET JWBS-10 band saw** to promote safety during installation, operation and maintenance procedures. Please read and understand the information contained in these operating instructions and the accompanying documents. To obtain maximum life and efficiency from your machine, and to use the machine safely, read this manual thoroughly and follow instructions carefully.

...Table of Contents

1. Declaration of conformity

2. Warranty

3. Safety

Authorized use

General safety notes

Remaining hazards

4. Machine specifications

Technical data

Noise emission

Dust emission

Contents of delivery

Machine description

Contents of shipping container

5. Transport and start up

Transport and installation

Assembly

Mains connection

Dust connection

Starting operation

6. Machine operation

7. Setup and adjustments

Changing the saw blade

Blade tension adjustment

Blade tracking adjustment

Blade guide adjustment

Thrust bearing adjustment

Miter gauge adjustment

Table tilting

90° Table Stop Adjustment

8. Maintenance and inspection

9. Troubleshooting

10. Environmental protection

11. Available accessories

1. Declaration of conformity

On our own responsibility we hereby declare that this product complies with the regulations* listed on page 2. Designed in consideration with the standards**. CE type examination*** conducted by****

2. Warranty

Tool France PROMAC, JPW Industries-Europe guarantees that the supplied product(s) is/are free from material defects and manufacturing faults.

This warranty does not cover any defects which are caused, either directly or indirectly, by incorrect use, carelessness, damage due to accidents, repairs or inadequate maintenance or cleaning as well as normal wear and tear.

Further details on warranty (e.g. warranty period) can be found in the General Terms and Conditions (GTC) that are an integral part of the contract.

These GTC may be viewed on the website of your dealer or sent to you upon request.

Tool France PROMAC, JPW Industries-Europe reserves the right to make changes to the product and accessories at any time.

3. Safety

3.1 Authorized use

This machine is designed for sawing wood, wood derived materials as well as similar to be machined hard plastics only.

Machining of other materials is not permitted and may be carried out in specific cases only after consulting with the manufacturer.

No metal workpieces may be machined.

The workpiece must allow to safely be loaded, supported and guided.

The proper use also includes compliance with the operating and maintenance instructions given in this manual.

The machine must be operated only by persons familiar with its operation and maintenance and who are familiar with its hazards.

The required minimum age must be observed

The machine must only be used in a technically perfect condition

When working on the machine, all safety mechanisms and covers must be mounted.

In addition to the safety requirements contained in these operating instructions and your country's applicable regulations, you should observe the generally recognized technical rules concerning the operation of woodworking machines.

Any other use exceeds authorization.

In the event of unauthorized use of the machine, the manufacturer renounces all liability and the responsibility is transferred exclusively to the operator.

3.2 General safety notes

Woodworking machines can be dangerous if not used properly. Therefore the appropriate general technical rules as well as the following notes must be observed.



Read and understand the entire instruction manual before attempting assembly or operation.

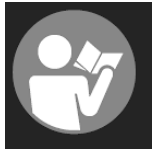

Keep this operating instruction close by the machine, protected from dirt and humidity, and pass it over to the new owner if you part with the tool.

No changes to the machine may be made.

Daily inspect the function and existence of the safety appliances before you start the machine.

Do not attempt operation in this case, protect the machine by unplugging the mains cord.

Remove all loose clothing and confine long hair.

Before operating the machine, remove tie, rings, watches, other jewellery, and roll up sleeves above the elbows.

Wear safety shoes; never wear leisure shoes or sandals.

Always wear the approved working outfit

- safety goggles
- ear protection
- dust protection

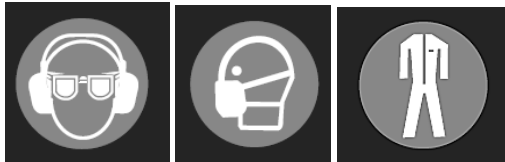

Do **not** wear gloves while operating this machine.



For the safe handling of saw blades wear work gloves.

Observe the chapter "safe operation" in this manual.

Control the stopping time of the machine, it may not be longer than 10 seconds.

Insure that the workpiece does not roll when cutting round pieces.

Use suitable table extensions and supporting aids for difficult to handle workpieces.

Always lower the blade guide close to the workpiece.

With the machine table is inclined use the fence and position it on the bottom side only.

Always hold and guide the workpieces safely during machining.

Remove cut and jammed workpieces only when motor is turned off and the machine is at a complete standstill.

Install the machine so that there is sufficient space for safe operation and workpiece handling.

Keep work area well lighted.

The machine is designed to operate in closed rooms and must be placed stable on firm and levelled ground.

Make sure that the power cord does not impede work and cause people to trip.

Keep the floor around the machine clean and free of scrap material, oil and grease.

Stay alert!

Give your work undivided attention. Use common sense.

Keep an ergonomic body position.

Maintain a balanced stance at all times.

Do not operate the machine when you are tired.

Do not operate the machine under the influence of drugs, alcohol or any medication. Be aware that medication can change your behaviour.



Keep children and visitors a safe distance from the work area.

Never reach into the machine while it is operating or running down.



Never leave a running machine unattended. Before you leave the workplace switch off the machine.

Do not operate the electric tool near inflammable liquids or gases.

Observe the fire fighting and fire alert options, for example the fire extinguisher operation and place.

Do not use the machine in a damp environment and do not expose it to rain.

Wood dust is explosive and can also represent a risk to health.

Dust from some tropical woods in particular, and from hardwoods like beech and oak, is classified as a carcinogenic substance.

Always use a suitable dust extraction device

Before machining, remove any nails and other foreign bodies from the workpiece.

Use a push block when working the ends of narrow stock.

Always store the push stick or the push wood handle with the machine, also when not in use.

Specifications regarding the maximum or minimum size of the workpiece must be observed.

Do not remove chips and workpiece parts until the machine is at a complete standstill.

Do not stand on the machine.

Connection and repair work on the electrical installation may be carried out by a qualified electrician only.



Have a damaged or worn cord replaced immediately.

Make all machine adjustments or maintenance with the machine unplugged from the power source.



Remove defective saw blades immediately.

3.3 Remaining hazards

When using the machine according to regulations some remaining hazards may still exist

The moving saw blade in the work area can cause injury.

Broken saw blades can cause injuries.

Thrown workpieces can lead to injury

Wood chips and sawdust can be health hazards. Be sure to wear personal protection gear such as safety goggles ear- and dust protection.

Use a suitable dust exhaust system.

The use of incorrect mains supply or a damaged power cord can lead to injuries caused by electricity.



4. Machine specifications

4.1 Technical data

Wheel diameter	255 mm
Cutting width	max 245 mm
Cutting height	max 100 mm
Sawblade length	1712 mm
Blade width	3 – 13 mm
Blade thickness	0,3 – 0,5 mm
Cutting speed	870 m/min
Machine Table(Lx W)	335x340 mm
Table tilting range	0° to 45°
Working height with stand	1055mm
Dust port diameter	100mm

Overall without stand (WxDxH)	686 x 457 x838mm
Weight without stand	34 kg

Overall with stand (WxDxH)	762 x496 x1511mm
Weight with stand	40 kg

Mains	1~230V, 50Hz
Motor Input power	600W S1
Reference current	2,7 A
Extension cord (H07RN-F):	3x1,5mm ²
Installation fuse protection	10 A
Insulation class	I

4.2 Noise emission

Determined according to EN 1807
(Inspection tolerance 3 dB)

Workpiece beech:

T=30mm, L=1500mm, moisture 8,5%

Acoustic power level

(according to EN ISO 3746):

Idling	LwA 85,0 dB(A)
Operating	LwA 96,4 dB(A)

Acoustic pressure level

(EN ISO 11202):

Idling	LpA 72,6 dB(A)
Operating	LpA 83,4 dB(A)

The specified values are emission levels and are not necessarily to be seen as safe operating levels. Although there is a correlation between emission and imission levels, these do not constitute a basis for determining the necessity of additional safety measures. Workplace conditions which could influence the noise imission level include the duration of resonance, spatial particulars, other noise sources etc. For example, the number of machines and other work being performed. The permissible workplace levels can vary from country to country.

This information is intended to allow the user to make a better estimation of the hazards and risks involved.

4.3 Dust emission

The band saw JWBS-10 has been dust emission inspected.

At an air velocity of 20 m/s on the dust port dia 100mm:

Vacuum pressure	1250 Pa
Volume flow	565 m ³ /h

The machine meets a workplace dust emission limit of 2 mg/m³.

4.4 Content of delivery

- Open stand
- Machine table
- Fence
- Fence support rails
- Mitre gauge
- Assembly bag
- Saw blade 10 mm
- Operating manual
- Spare parts list

4.5 Machine description



Fig. 1

- A.....Sawblade tension knob
- B.....Upper viewing window
- C.....Control wheel Upper blade guide
- D.....Machine lamp
- E.....Upper blade guard
- F..... Rip fence
- G.....Sawblade
- H.....Mitre gauge
- I.....Blade tension lever
- J.....Saw table
- K.....Tracking knob
- L.....Wheel locking blade guide
- M.....Switch
- N.....Motor assembly
- O.....Extension table
- P.....Dust extraction nozzle
- Q.....Knob for the table
- S.....Knob for Saw Door

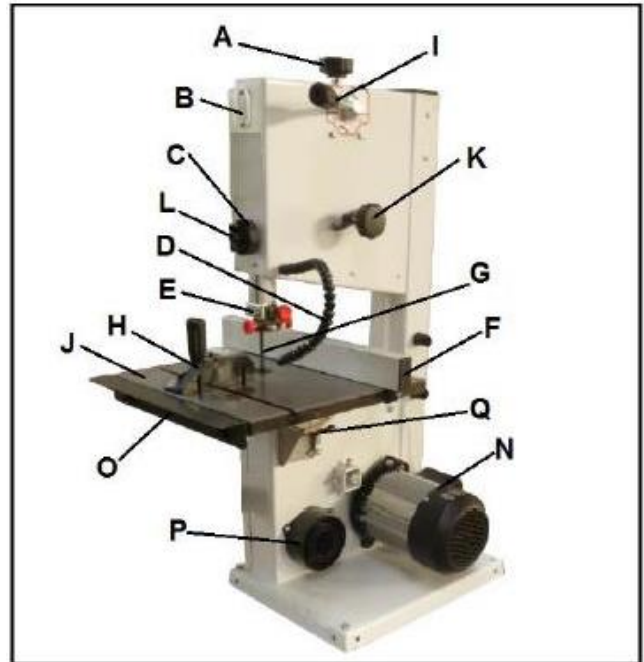

Fig. 2

4.6 Contents of shipping container

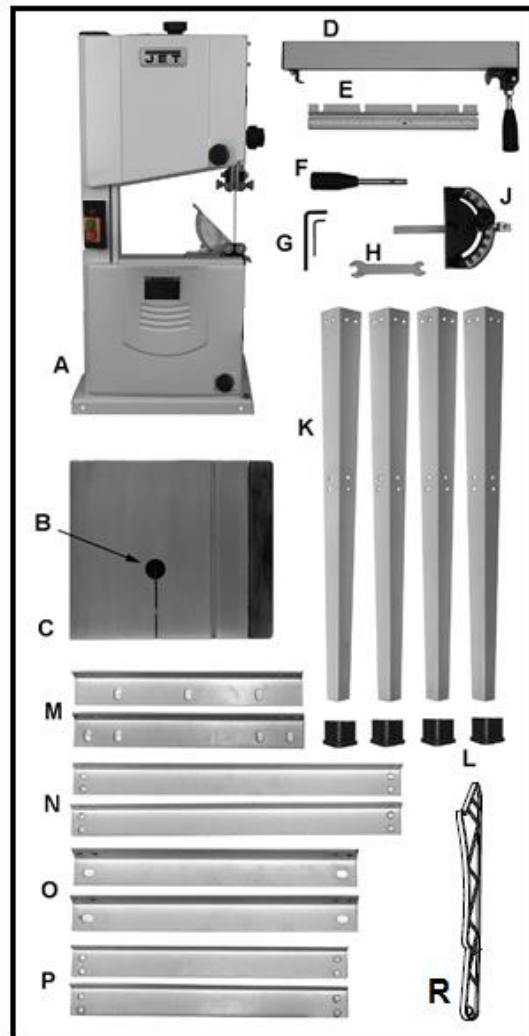

Fig.3

Refer to Figures 3 and 4.

- 1 Band saw – **A**
- 1 Table insert – **B**
- 1 Table – **C**
- 1 Fence – **D**
- 1 Guide rail – **E**
- 1 Handle – **F**
- 2 Hex wrenches, 3mm,6mm – **G**
- 1 Wrench – **H**
- 1 Miter gauge – **J**
- 4 Stand legs – **K**
- 4 Rubber foot – **L**
- 2 Short support plate – **M**
- 2 Long cross brace – **N**
- 2 Long support plate – **O**
- 2 Short cross brace – **P**
- 1 Push Stick---**R**
- 1 Owner's Manual (not shown)
- 1 Part List (not shown)
- 1 Hardware package

Hardware package (JWBS10-HP), includes:

- 3 Hex cap screw, M8x55 – **HP1**
- 4 Hex washer head screw, M6x12 – **HP2**
- 32 Carriage bolt, M6x12 – **HP3**
- 4 Wing screw – **HP4**
- 4 Flat washer blk oxide M8 – **HP5**
- 6 Flat washer M8 – **HP6**
- 3 Lock washer M8 – **HP7**
- 3 Hex nut, M8 – **HP8**
- 32 Hex flange nut, M6 – **HP9**

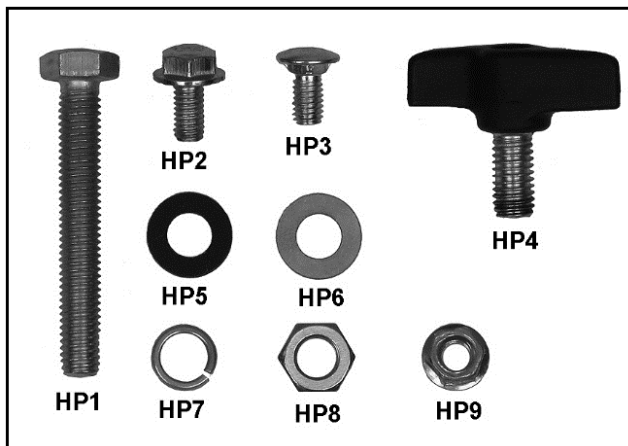

Fig. 4

5. Transport and start up

5.1 Transport and installation

For transport use a forklift or hand trolley. Make sure the machine does not tip or fall off during transport.

The machine is designed to operate in closed rooms and must be placed stable on firm and levelled ground.

Stability of bandsaw.

Before using the bandsaw, ensure the machines upright stability is satisfactory.

The bandsaw has three Ø8mm holes (A, Fig 5 Fig.6 Fig.7) in it's base to allow it to be bolted to a workbench or to the supplied open stand

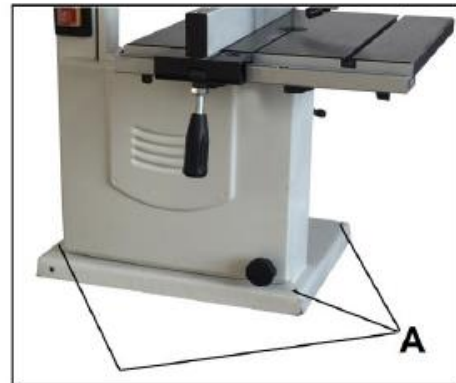

Fig. 5

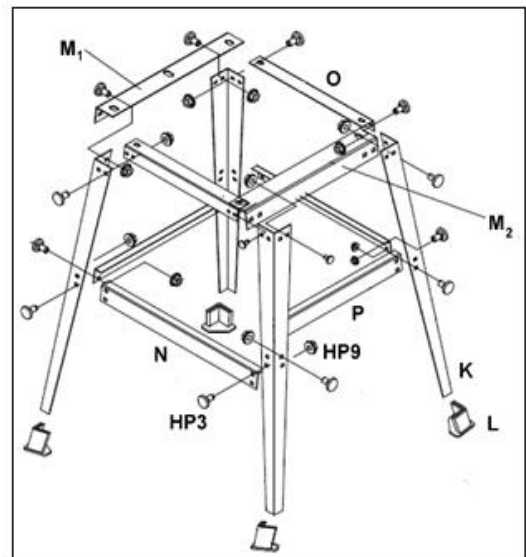

Fig.6

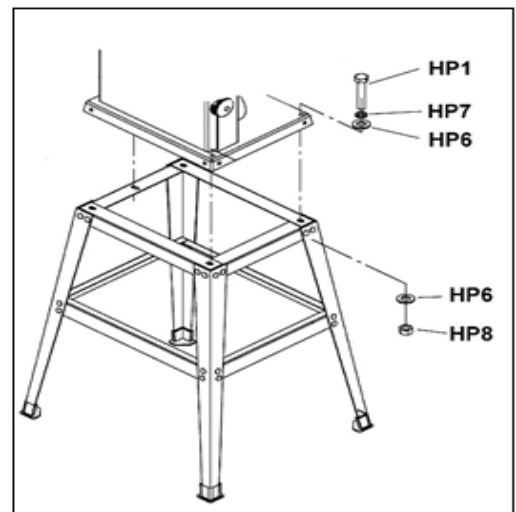

Fig. 7

For packing reasons the machine is not completely assembled.

Refer to Figure 6, Figure 7 to assemble stand. Use carriage bolts (HP3) and flange nuts (HP9) throughout. Only hand-tighten all fasteners at this time.

Make sure the two short support plates with extra holes (M) are opposite one another as shown.

Slip rubber feet (L) onto ends of stand legs.

Place stand upright on level floor, and push down until it sits evenly.

Tighten all nuts on stand assembly.

5.2 Assembly

If you notice any transport damage while unpacking, notify your supplier immediately. Do not operate the machine!

Dispose of the packing in an environmentally friendly manner.

Clean all rust protected surfaces with a mild solvent.

Prior to use, the following items have to be fitted:

Bandsaw table, Rip fence guide and Crank handle.

Fitting the table

Refer to Figure 8.

Loosen lock handle (shown in Figure 9) and pivot trunnion (A1) to horizontal position.

Loosen lock knob (C2) and pull extension (C1) out from the table (C).

Orient table as shown, then maneuver to allow saw blade (A2) to pass through slot (C3) to the center.

Line up four threaded mounting holes underneath table with the four mounting through-holes on trunnion.

Important: Adjust table so miter slot (C4) is parallel with saw blade (A2).

Secure with four M6x12 hex washer head screws (HP2). Tighten with 13mm wrench.

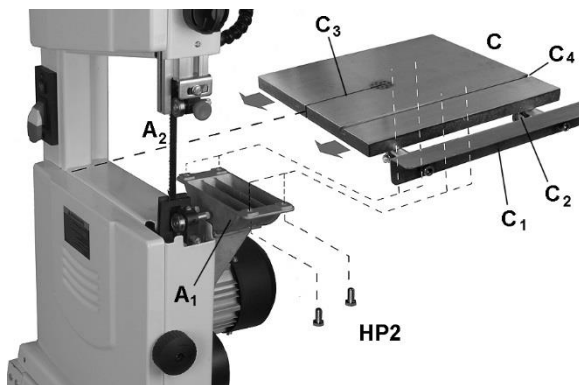

Fig. 8

Fitting Guide rail and fence

Attach guide rail (E, Figure 9) to front of table. Secure with four wing screws (HP4) and flat washers (HP5).

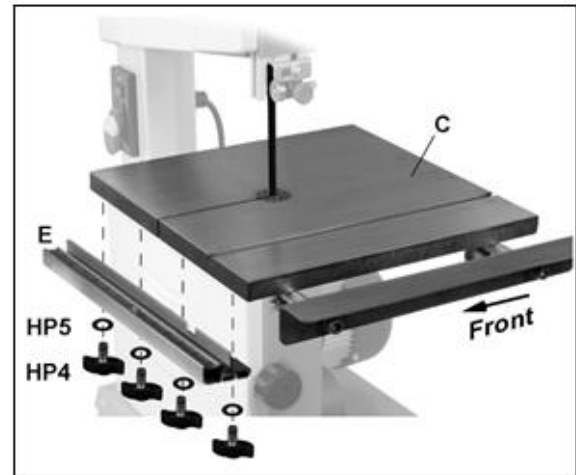

Fig. 9

Refer to Figure 10:

Place fence assembly (D, Figure 10) onto table at the miter slot.

The rear hook should engage the rear of the table. The fence body should engage the guide rail (E).

If the fence is not parallel to the miter slot:

Loosen two socket head cap screws (S1) with a 4mm hex wrench. End cap (S2) may need to be removed.

Adjust fence so it is parallel to miter slot.

Lock the fence handle, securing it to the guide rail (E), and verify that fence is still parallel to miter slot.

Retighten two screws (S1) to secure fence to the fence body and replace end cap (S2).

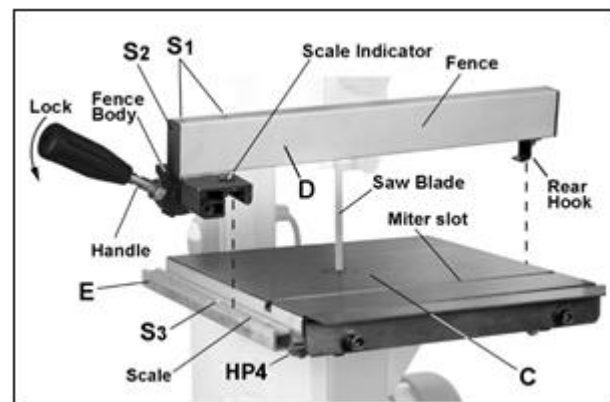

Fig. 10

Fence scale adjustment

Refer to Figure 10:

Place fence assembly (D) onto table (C) **against** the saw blade. Lock fence.

If the hairline on the scale indicator does not point to zero:

Remove fence assembly (D).

Loosen screw (S3) that secures scale to guide rail (E).

Repeat step 1, then slide scale until hairline on scale indicator points to zero.

Being careful not to move the scale, unlock and lift fence from the table.

Tighten screw (S3) to secure scale in position.

If further adjustment is needed, wing screws (HP4) can be loosened to allow adjustment of guide rail (E).

Quick-tension handle

Install quick-tension handle into hub on back of saw. (see Q, Figure 11), and tighten using a wrench on the flat of the shaft.

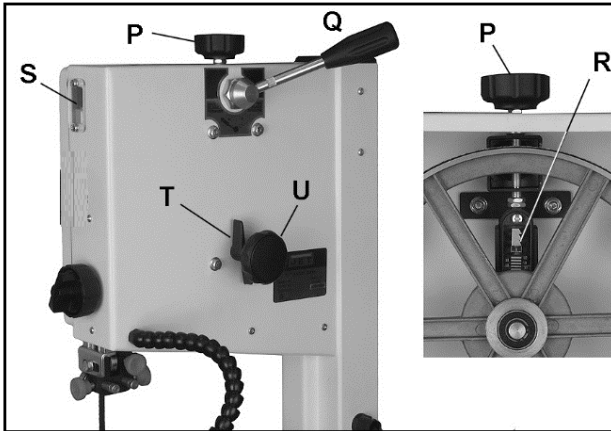

Fig. 11

Setting the table square to sawblade

Tools Required : Small 90 ° square (*not supplied*)

The table can be set at 90° to the sawblade by adjusting the table stop screw underneath the table. Fig. 12

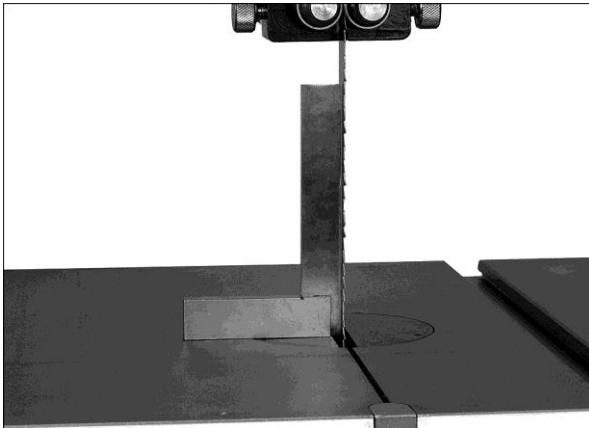

Fig 12

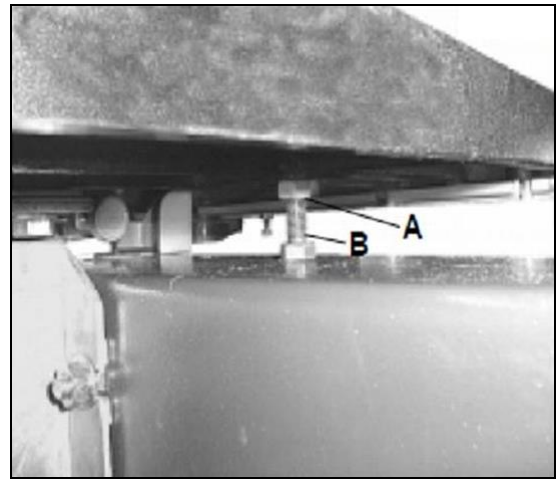

Fig. 13

Checking the table for flatness

A steel rule should be held on the table across the table slot close to the front edge of the table. (See Fig. 14)

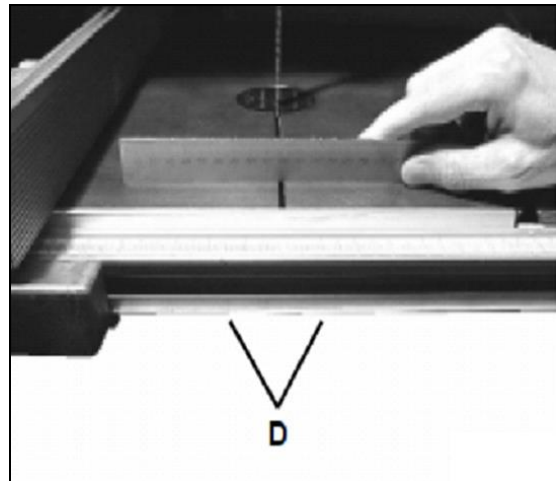

Fig. 14

If the straight edge shows there is a step across the table slot then the table needs to be adjusted using the two screws and locking nuts provided for this purpose, located on the underside of the rip fence guide, at (D, Fig 14)

Lower blade guard

When open the lower bandwheel door on this machine the lower blade guard (Fig 15).

Refer to Figure 13:

Loosen the nut (A, Fig 13), adjust bolt (B).

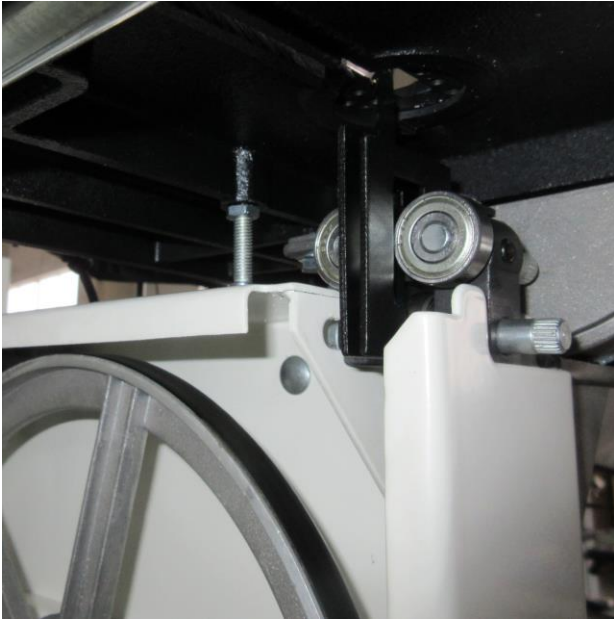

Fig 15

The bandwheel doors **MUST** be closed at all times when the machine is being operated.

5.2 Mains connection

Mains connection and any extension cords used must comply with applicable regulations.

The mains voltage must comply with the information on the machine licence plate.

The mains connection must have a 10 A surge-proof fuse.

Only use power cords marked H07RN-F

Connections and repairs to the electrical equipment may only be carried out by qualified electricians.

5.3 Dust connection

The machine is equipped with a dust port dia 100mm (B, Fig. 16). The dust port is located at the back of the band saw for mounting a hose (not provided) to connect a dust collector or shop vacuum.

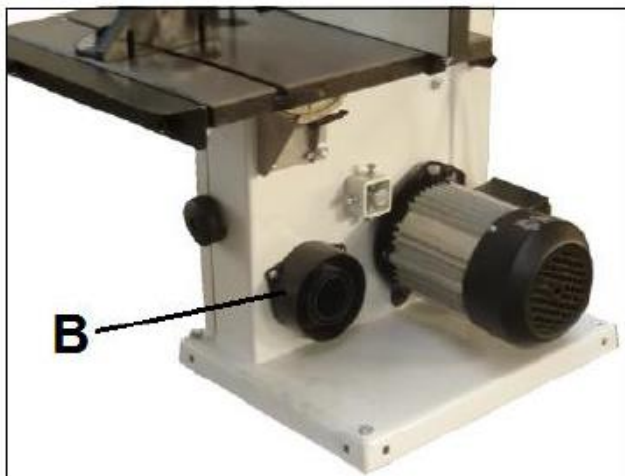

Fig. 16

Before initial operation, the machine must be connected to a dust extractor. The suction should switch on automatically when the bandsaw is switched on.

The flow rate on the suction port must be 20m/sec. Flexible hoses must be of non-flammable quality, and must be connected to the machine ground system.

5.4 Starting operation

Magnetic(On/Off) Switch – located on front of machine: You can start the machine with the green on button. The red button on the main switch stops the machine.

Work Lamp Switch – located on front of machine above On/Off switch. Turns LED work lamp on and off.

6. Machine operation

Correct working position:

In front of the machine standing in the direction of cutting.

Workpiece handling:

Hands placed flat on the workpiece outside the cutting area. Feed the workpiece towards the saw blade in the direction of the saw line, and cut as required by turning to follow the line drawn. Push the workpiece steadily forward; complete the cut as a single movement. Do not draw the workpiece back, as this could cause the sawblade to run off its wheels.

Support long and wide workpieces with helping roller stands.

Operating hints:

Work only with a sharp and flawless sawblade.

Near the cutting area use a push stick to feed.

Use a feeding template to safely guide small and narrow workpieces.

Use a suitable wedge to prevent round timber from turning under the pressure of the cut

Workpiece setup:

Bring the upper blade guide to a distance of approx 2-5mm to the workpiece. (See Fig 17).

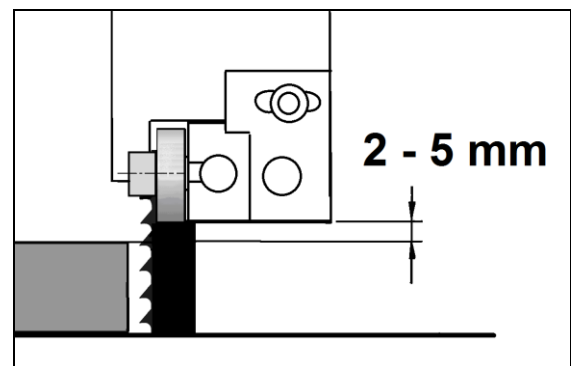

Fig. 17

For your own safety, always set the saw guide as close to the workpiece as possible.

To adjust the cutting height release the winged nut (A, Fig 18) and move the upper blade guide and guard assembly (B).

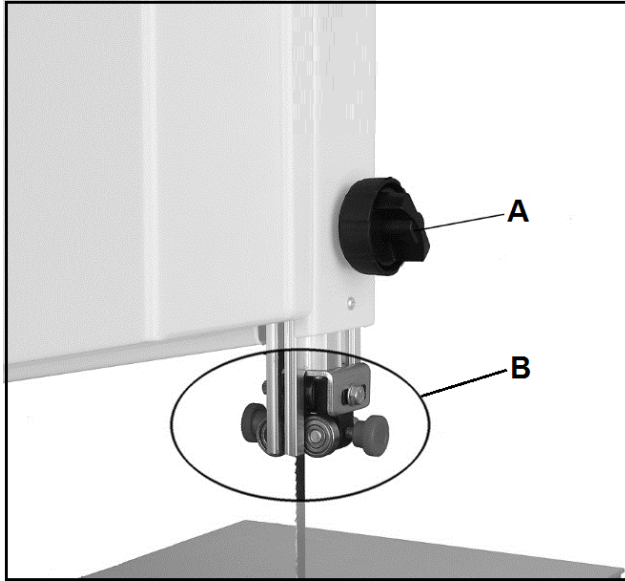

Fig. 18

Blade Drift Compensation:

Blade drift is a frequent problem on rip cuts and during resawing.

Blade drift may occur when the fence is being used, the blade begins to wander off the cutting line (Fig. 19).

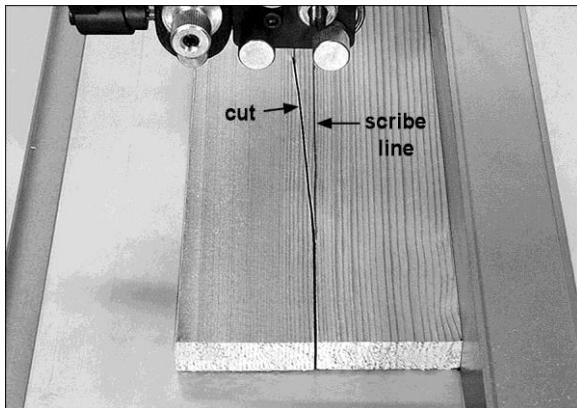

Fig. 19

Blade drift can be caused by a number of factors.

- The saw blade follows the grain
- The saw blade is dull.
- Blade guides not adjusted correctly.
- Blade tension insufficient.
- Blade-teeth have asymmetric "set"

Auxiliary fence for rip fence:

For your own safety always set the upper saw guide as close to the workpiece as possible.

For narrow shallow cuts on the rip fence a self-made auxiliary fence (E, Fig. 20) made of cuttable material (e.g. wood, plastic, aluminium) must be used. Length same as rip fence.

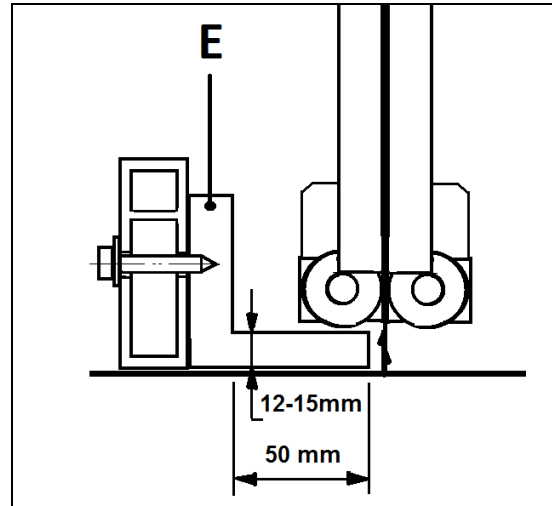
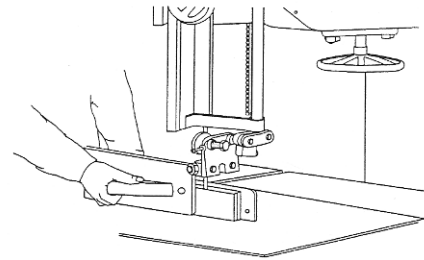
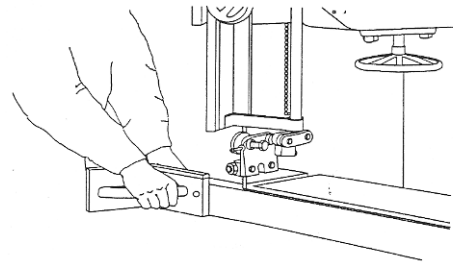

Fig. 20

Mitre gauge:

Place the mitre gauge in the table T-slot.

Directions for "safe operation" :



Performing high resaw cuts

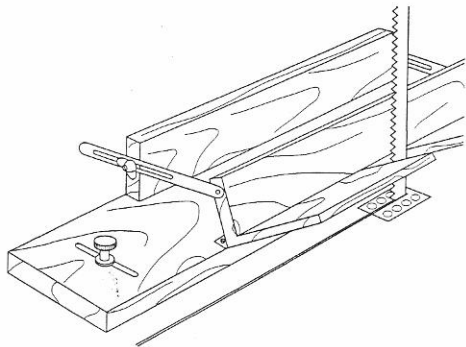
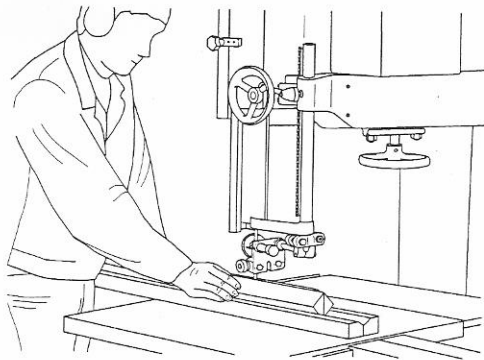

Performing diagonal cuts

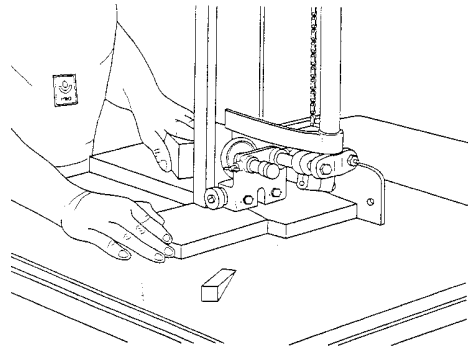
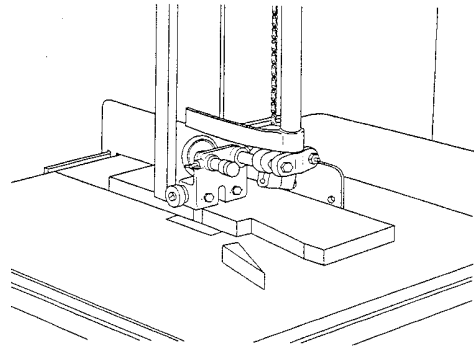

Cutting of wedges

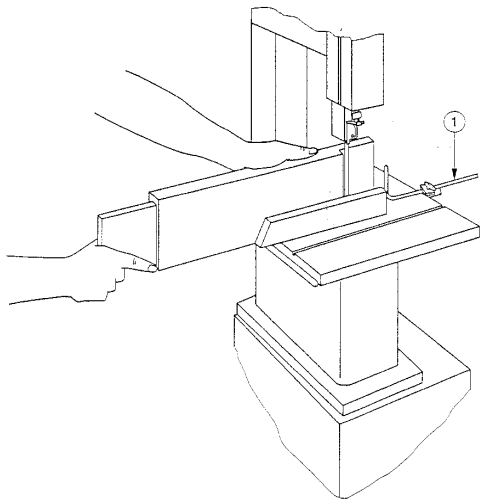

Tenon cutting

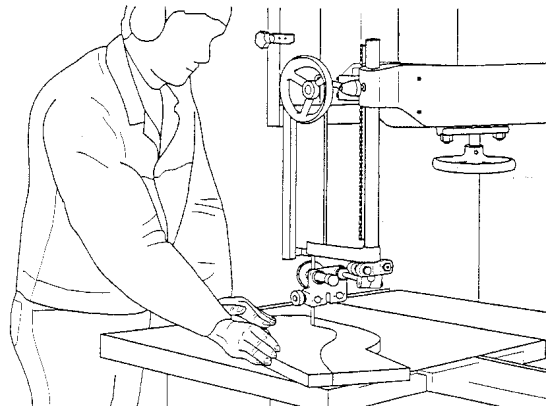

Curved cuts

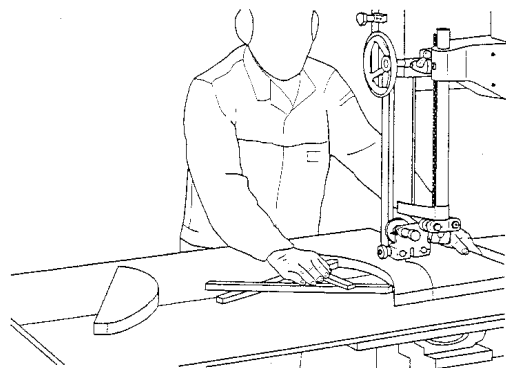

Arc cuts

7. Setup and adjustments

General note:

Setup and adjustment work may only be carried out after the machine is protected against accidental starting by pulling the mains plug.

7.1 Changing the sawblade

The sawblade has to meet the technical specification.

Choose a suitable sawblade, according to the cutting operation and according to the material to be cut.

For high rip cuts:

- use a wide sawblade (e.g. 13mm), coarse teathed.

For narrow curved cuts:

- use a narrow sawblade (e.g. 6mm).

Check sawblade for flaws (cracks, broken teeth, bending) before installation. Do not use faulty sawblades.

The sawblade teeth must point in cutting direction (down)

Always wear suitable gloves when handling sawblades.

The sawblades may only be changed when the mains plug is pulled!

Replacing the bandsaw blade

Note: The JWBS-10 Band Saw comes equipped with a factory-installed 1712x9.5x0.35(67.5" x 0.375" x 0.014"), 6TPI blade .

Disconnect machine from power source.

Open upper and lower doors (Figure 22) by rotating the knobs.

Loosen lock knob (G, Figure 21) and pull extension (H, Figure 22) away from table.

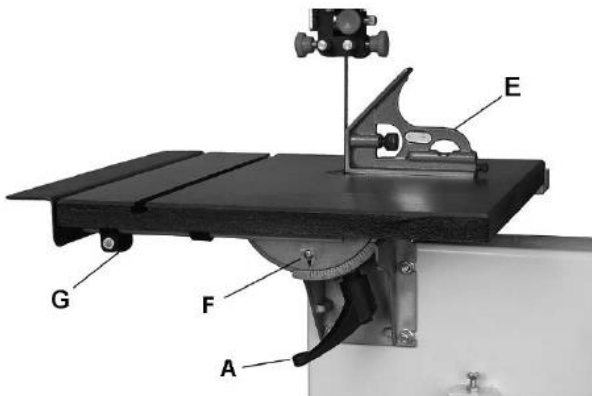

Fig.21

Remove guide rail (E, Figure 9).

Release tension on blade by moving tension handle (Q, Figure 23) to the right.

Refer to Figure 22:

Remove blade from upper and lower wheels (K,L) and from between upper and lower blade guides (M,N).

Remove blade through slot (O) in table.

Guide the new blade through table slot (O) leading with the smooth edge. Place it around the upper and lower wheels and into the upper and lower blade guides (M,N).

Note: The blade teeth should face the operator, and they should point down toward the table.

Position the blade to track in the middle of the rubber tires on the wheels (K,L).

Engage tension on the blade by moving quick tension handle (Q, Figure 23) to the left.

Replace guide rail (E, Figure 9).

Before operating the saw, check that the blade is tracking and has proper tension.

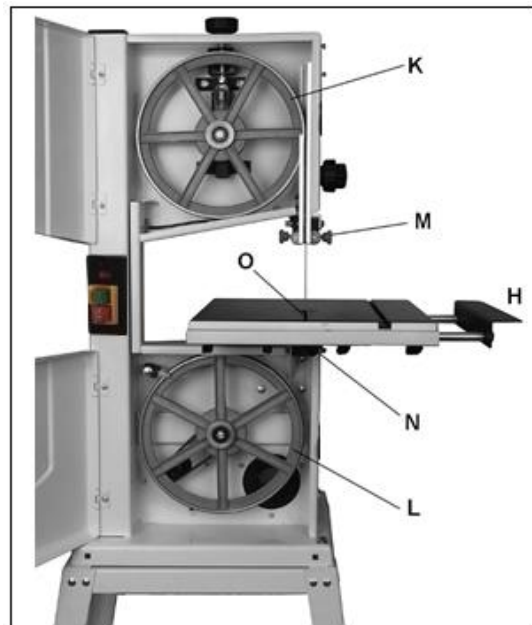

Fig. 22

7.2 Blade tension adjustment

Refer to Figure 23:

The blade tension knob (P) is used to adjust blade tension.

The quick tension lever (Q) must be engaged (moved to the left) before making tension adjustments with knob (P).

All bearings on upper and lower guides must be clear of blade.

Disconnect machine from power source.

Apply just enough tension to take slack out of blade.

Turn one wheel a few times to allow blade to position itself in center of tire.

Note: If blade does not center, Adjusting blade tracking.

A gauge (R) directly behind upper wheel indicates approximate tension according to width of blade. Set blade tension with knob (P) to correspond to blade width as marked on gauge (R).

Note: A tension meter is recommended to precisely set tension for the size of blade used.

As you become more experienced with the saw, you may find it necessary to change the blade tension from the initial setting. Changes in blade width and the type of material being cut will have an effect on blade tension.

Keep in mind that too little or too much blade tension can cause blade breakage.

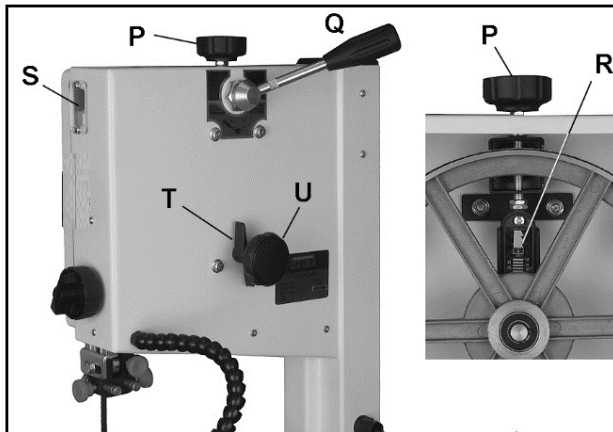

Fig. 23

7.3 Blade tracking adjustment

Refer to Figure 23:

Tracking refers to how the blade is situated upon the wheels while in motion. The blade should track in the center of both wheels.

The blade must be slightly tensioned before adjusting blade tracking. Make sure blade guides and bearings (M,N, Figure 22) do not interfere with blade. If blade tracking is required, blade guide adjustment is described in section to "Guide bearing adjustment".

Open upper and lower doors. Rotate upper wheel forward by hand, and observe position of blade on wheel through the window (S, Figure 23). Blade should be in the center of the wheel.

If adjustment is necessary:

Loosen handle (T) and make adjustment with tracking knob (U) while rotating wheel by hand.

Tightening the tracking knob slightly will move the blade so it tracks towards the rear of machine. Loosening the tracking knob slightly will cause the blade to track toward the front of the machine.

After blade is tracking in the center of the wheel, tighten handle (T).

Upper blade guide positioning

Refer to Figure 24:

The upper blade guide assembly (W) should be adjusted to just above the material being cut. To adjust:

Loosen lock knob (V) and raise or lower upper blade guide assembly (W) by turning height adjustment knob (X).

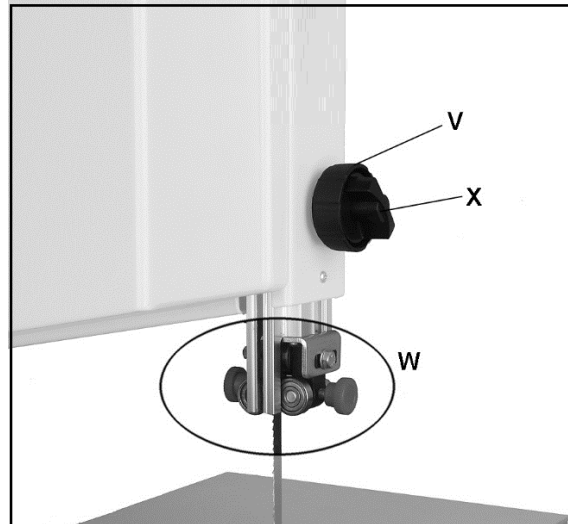

Fig. 24

7.4 Blade guide adjustment

Overview

The blade guide assembly consists of two roller guides (bearings) positioned on each side of the blade to provide blade stability. A third guide (thrust bearing) is positioned behind the blade to provide blade support.

There are two blade guide assemblies – an upper assembly (Figure 25) and lower assembly (Figure 26).

Adjustments are performed in the same manner for each assembly. Each assembly must be adjusted in turn using the adjustment procedures outlined below.

7.5 Thrust bearing adjustment

Refer to Figures 25 and 26:

Note: Blade must already be tensioned and track-ing properly.

Disconnect machine from power source.

For the upper thrust bearing, loosen thumb-screw (A, Figure 25). For the lower blade guide, loosen setscrew (A, Figure 26) with the 3mm hex wrench provided.

Slide the adjustment shaft (C) so the blade is positioned in the middle of the thrust bearing (D).

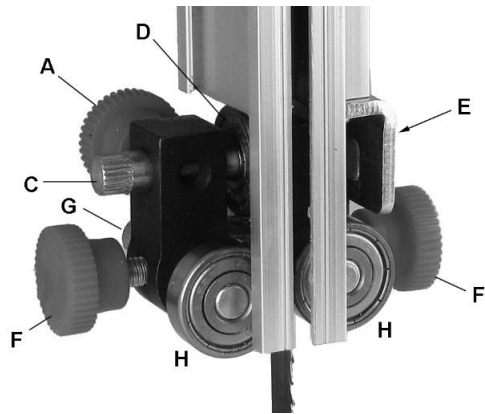

Fig. 25: upper blade guides

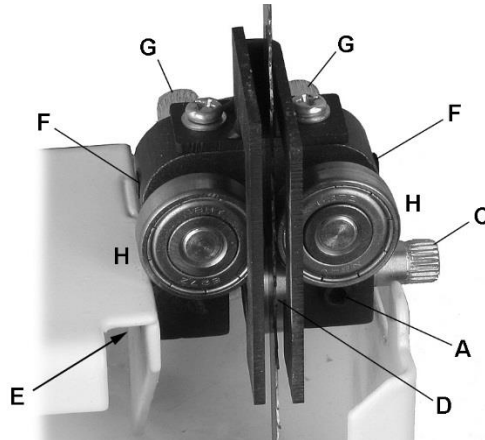

Fig. 26: lower blade guides

The thrust bearing (D) is mounted on a concentric shaft (C). When the shaft is rotated, the relative position of the bearing to the back of the blade can be changed.

Rotate the adjustment shaft (C) so the thrust bearing (D) just clears the back of the saw blade.

Tighten thumbscrew/setscrew (A).

NOTE: If a blade is being replaced with a new one of a different size, the adjustment described above may fall out of range and further adjustment may be required as follows:

Loosen the socket head screw (E, not visible) with a 10mm wrench and adjust the entire assembly back or forth to just clear the back of the saw blade. Tighten screw (E), then fine tune the adjustment by repeating the first part of this step.

Secure the thrust bearing (D) by tightening the thumbscrew (A, upper guide) or setscrew (A, lower guide).

Guide bearing adjustment

Refer to Figures 25 and 26:

Note: Blade must already be tensioned and tracking properly .

Disconnect machine from power source.

For upper blade guide, loosen two thumb-screws (F). For lower blade guide, loosen two setscrews (F) with the 3mm hex wrench provided.

Slide adjustment shaft (G) to position each guide bearing (H) approximately 1/16" behind the gullets of the saw blade.

The guide bearing (H) is mounted on a concentric shaft. When the shaft (G) is rotated, the relative position of the guide to the blade can be changed.

Rotate each adjustment shaft (G) to position the guide bearings (H) within 1/32" of the saw blade.

Secure the guide bearings (H) by tightening thumbscrews (F, upper guide) or setscrews (F, lower guide).

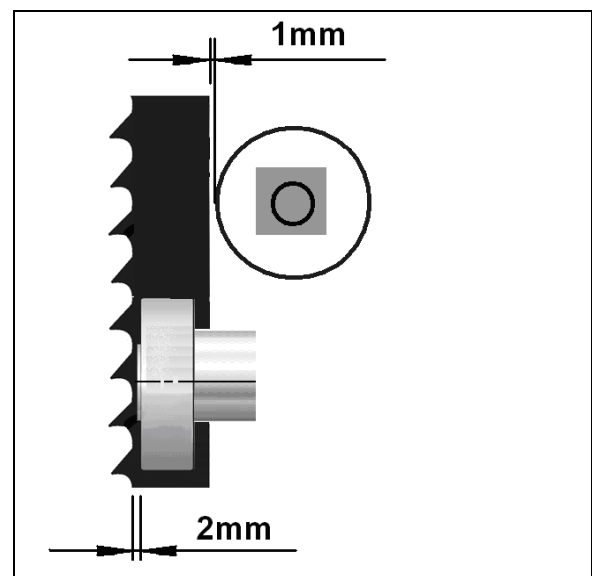

Fig.27

7.6 Miter gauge adjustment

Refer to Figure 28:

To adjust angle of miter gauge, loosen handle (J) and rotate gauge body. Tighten handle.

Place miter gauge into table slot and use a square to verify that 90-degree setting on scale is 90-degrees to slot. Adjust pointer (K) if necessary.

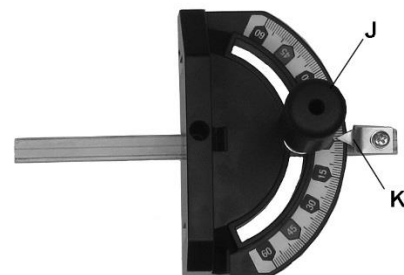

Fig. 28

7.7 Tilting table

Refer to Figure 29:

Loosen lock knob (A).

Tilt table up to 45 degrees to the right or down 5 degrees to the left. The angle can be read on the scale (B) on the trunnion bracket.

Note: Table perpendicular (90°) to the blade corresponds to a scale indication of 0°.

Tighten lock knob (A).

Note: The table stop (C) must be adjusted to permit the table to tilt to the left.

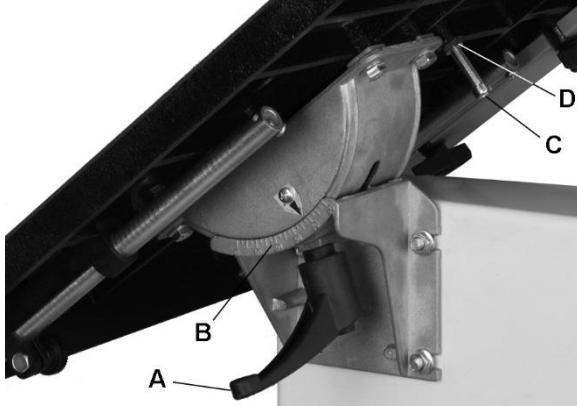

Fig.29

NOTE: Lock handle (A, Figure 29) is adjustable – pull down on handle and rotate on pin. Release handle, making sure it settles back onto pin.

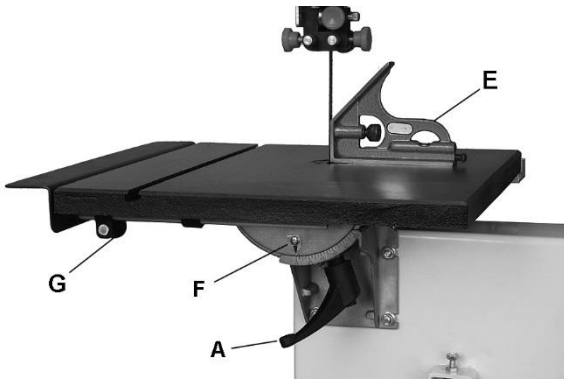

Fig.30

7.8 90° Table Stop Adjustment

7.8.1 Adjusting table stop

Refer to Figures 29 and 30.

The table stop (C, Figure 29) is typically set to stop the table at 90° (perpendicular) with the blade.

Disconnect machine from power source.

Loosen lock knob (A, Figure 29); then tilt table down, bringing it to rest against table stop (C, Figure 29).

Use a square (E, Figure 30) placed on the table and against the blade, to verify that table is 90° to blade.

If an adjustment is necessary, tilt table up to access table stop (C, Figure 29).

Loosen jam nut (D, Figure 29) and turn table stop in or out to raise or lower the stop. Tighten the jam nut to hold table stop in place.

Tilt table back to level, letting it rest against the stop and confirm table is 90° with the blade as described in step 3.

For left tilt down to 5°, the table stop (C, Figure 9) must be adjusted further.

7.8.2 Adjusting table tilt indicator

Set table at 90° with blade.

Confirm that table tilt indicator (F, Figure 30) points to zero.

If adjustment is required:

Slightly loosen screw securing indicator, adjust indicator to point to zero; then re-tighten screw.

Test run:

Turn the wheels by hand and inspect the adjustments made.

Start the machine with care.

Note:- When using the table at an angle always have the rip fence on the lower side of the table to support the workpiece.

8. Maintenance and inspection

General notes:

Maintenance, cleaning and repair work may only be carried out after the machine is protected against accidental starting by pulling the mains plug.

Repair and maintenance work on the electrical system may only be carried out by a qualified electrician.

Clean the machine regularly.

NEVER USE WATER OR OTHER LIQUIDS TO CLEAN THE MACHINE. USE A BRUSH.

Keep the ventilation slots of the motor clean to prevent it from overheating.

Inspect the proper function of the dust extraction daily.

All protective and safety devices must be re-attached immediately after completed cleaning, repair and maintenance work.

Defective safety devices must be replaced immediately.

Inspect the correct blade tension regularly. Take away the blade tension if the machine is not in use for a longer time period.

Inspect the blade guide adjustment regularly.

Wheels:

The rubber tyre of the wheels must be cleaned regularly.

The upper wheel support must be lubricated regularly.

Table insert:

Replace a worn table insert.
The table insert may not project above table surface.

The table insert must be made out of cuttable material (e.g. wood, plastic, aluminium)

The table insert may not project above table surface.

Saw blades:

The servicing of saw blades should only be performed by a trained person.

Only use sharp and properly set saw blades.

Replacing drive belt:

The belt tension must be inspected regularly.

Disconnect machine from power source.

Open upper and lower doors.

Remove saw blade as described.

Refer to Figure 31:

Remove tension on drive belt (L) by loosening the socket head screw (13mm wrench required) on the back of the cabinet that secures the motor.

Using snap ring pliers, remove snap ring (M) that secures lower wheel (N) to shaft (O).

Slide lower wheel assembly off the shaft (O) which will dislodge the belt (L). Discard the old belt.

Place new belt onto lower wheel pulley.

Reinstall lower wheel assembly by sliding it back onto the shaft (O).

Reinstall snap ring (M).

Place new belt (L) partially around motor pulley (P) to get it started, then turn wheel (N) by hand until belt is completely seated on motor pulley (P).

Push the motor down to add tension to belt. The belt is properly tensioned when moderate finger pressure on the belt between the two pulleys causes a 1/2-inch deflection.

Tighten socket head screw on the back of the cabinet that secures the motor.

Re-install blade.



Fig.31

Adjusting drive belt tension:

Refer to Figure 31:

Disconnect machine from power source.

With a 13mm wrench, loosen socket head screw on back of cabinet that secures the motor.

Push motor down to add tension to belt.

The belt is properly tensioned when moderate finger pressure on the belt between the two pulleys causes a 1/2" deflection.

Tighten socket head screw that secures motor.

9. Trouble shooting**Motor doesn't start**

*No electricity-
check mains and fuse.

*Defective switch, motor or cord-
consult an electrician.

Machine vibrates excessively

*Stand on uneven floor-
adjust stand for even support.

*dust on wheel-
clean tires.

*sawblade has cracks-
replace sawblade immediately

Cut is not square

*Table stop setting wrong.
*Blade guide setting is bad

Cutting surfaces is bad

*Wrong sawblade used
*resin collection on sawblade
*sawblade is dull
*Blade guide setting is bad
*Blade tension too low
*workpiece inhomogeneous
*Feed pressure too high-
Do not force the workpiece.

10. Environmental protection

Protect the environment.

Your appliance contains valuable materials which can be recovered or recycled. Please leave it at a specialized institution.

11. Available accessories

Refer to the JET-Price-list